



Electric Bike Conversion Kit

Installation's Manual

V.1.6

May 2015



## Table of contents:

|   | Page |
|---|------|
| 1. Before installation                          | 3    |
| 2. Recommendation for washing                   | 3    |
| 3. Installing the motor                         | 3    |
| 4. Installing the battery unit                  | 6    |
| 5. Installing the pedal assist sensor           | 7    |
| 6. Fitting the LCD console                      | 9    |
| 7. Installing the brake cut off switches        | 10   |
| 8. Connecting the connectors                    | 11   |
| 9. Connecting brake lever & throttle to the LCD | 12   |

This manual applies to the OXYDrive CST 11Ah, CST 13Ah HT conversion kits.

PLEASE NOTE: Not all the illustrations may apply to your specific kit. This is a DIY conversion kit and some illustrations may vary from the actual product purchased. The entire concept of fitting is the same on all kits. Also note that installation of various bikes may vary and there may be a need to take an individual approach for every bike conversion. OXYDrive does not take any liability for the damages caused to the bike frames or any other bike components. The conversion kits are fitted at owner's risk. There is no guarantee that the conversion kit will fit without any problems to any bike.

## 1. Before installation

Before installing this kit please note that there is a minimum skills required to run a successful installation. If the end user feels uncomfortable to carry on the assembly process it is advised to take it to the nearest dealer or good bicycle shop with workshop facilities. To run a successful installation the assembler will need the basic workshop tools too. Please read the next chapter

**OX**YDrive

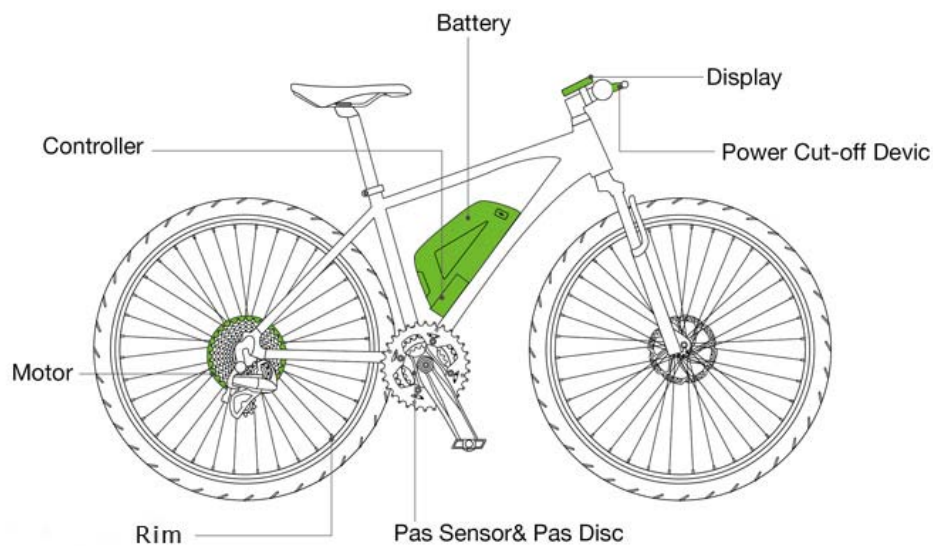

## 2. Tools required for installation

All good bicycle workshops will have all necessary tools to carry on the assembly process:

Tools required for installation:

- Set of allen (hex) keys, 2-6mm
- Cassette wrench
- Cable cutters
- 19mm spanner (wrench)
- Set of tyre levers

- Bicycle pump
- Flat and cross screwdrivers

### **3. Installing the motor**

#### **Step 1**

Fit the bicycle tyre along with the rim tape to the new OXYDrive wheel.

#### **Step 2A Fitting front wheel motor**

Try to slot the motor into the forks drop outs. Please note that some forks may only have a 9mm drop outs. The motor axle is 10mm and therefore may not fit.

**IMPORTANT:** The motor's axle must slot in to the dropouts easily with no use of any force. If you fork drop out is too narrow please use a file to file off the surface by 0.5 mm on each side.

#### **STEP 2B: Fitting rear wheel cassette motor**

Before fitting the rear cassette motor into frame dropouts please fit the cassette on the motors ratchet. You need to use the cassette tool to tight up the cassette. The amount of torque used to tighten up cassette should be specified on the locking nut of each cassette. Always use good quality 19mm spanner to secure the locking nuts in the frame.

#### **Step 3**

When fitting the motor regardless if its front or rear driven it is generally better to direct the motor cable towards the bottom. It will prevent then any possibility of water getting into the motor. For mountain bike users this position of motor cable brings higher risk of ripping the motor cable in the off road terrain.

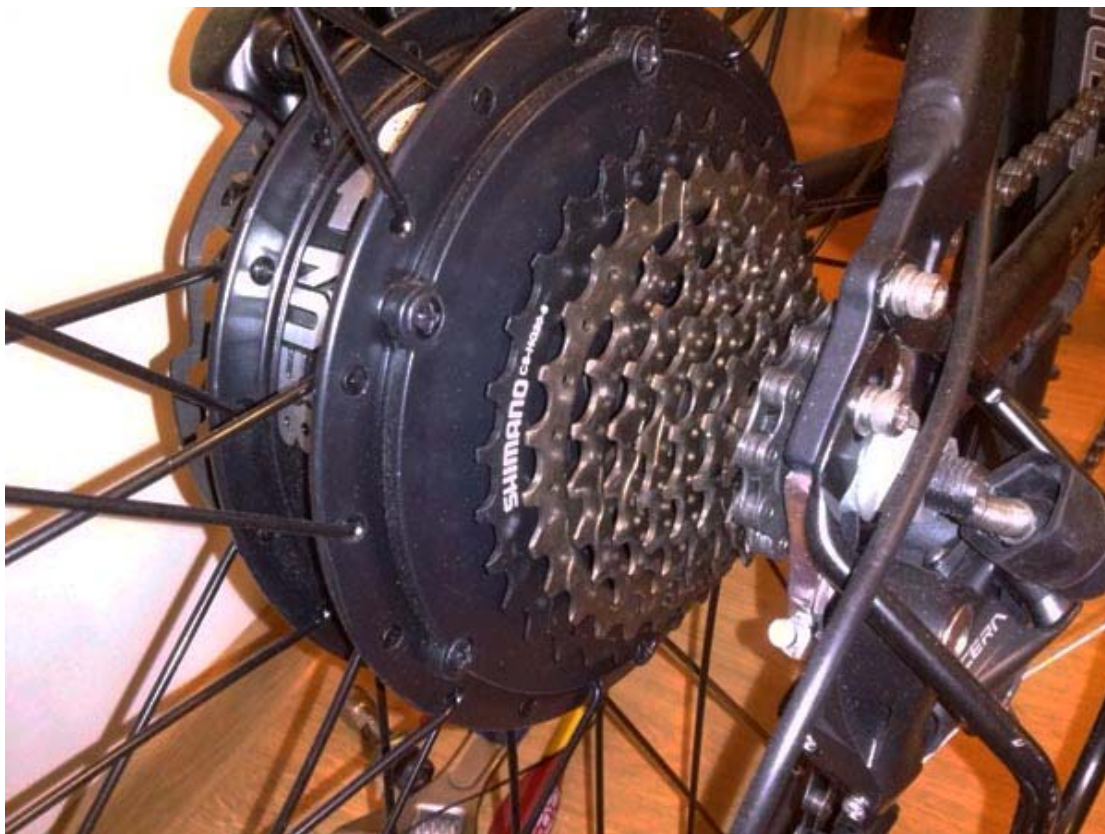

#### **Step 4.**

It is crucial to pay extra attention of the order of fitting the locking nuts.



*Motor's axle must fully slot into frame drop-outs and secured with washer and locking nut*

#### **Step 5.**

##### **For rear wheel driven kit**

Securing the front wheel is very important. The locking nuts should be well tight with a minimum torque of 12Nm.

**IMPORTANT:** The locking nuts and spokes should be regularly checked every few rides to ensure the wheel is securely fitted.

## **4. Installing the battery unit**



The battery holding unit should be fitted normally in the place of the water bottle cage. Most of the bicycles already have ready made frame mounts where the water battery holding unit can be attached to.

This manual does not give any recommendations on the bolts size or torque as it all depends on the each individual frame requirements. Please note that battery holding unit should be well secured to the frame. Please use at least the same torque as for the water bottle cage. For frames with a very think tubes it is advised to add additional double sided counting tape (not included)

### **Warning to high performance tubing**

Please note that some manufacturers' use high performance double or even triple butted tubing's to reduce the weight of the frame. It means that frame's tubing's are very weak in some sections and should not be pressed with any kind of clamps. Please pay extra attention when securing your battery holding unit with additional zip ties to avoid the damage to the frame. OXYDrive does not recommend to fit these conversion kits on the carbon frames.

## Fitting the battery

In order to fit the battery follow the steps shown on the image below

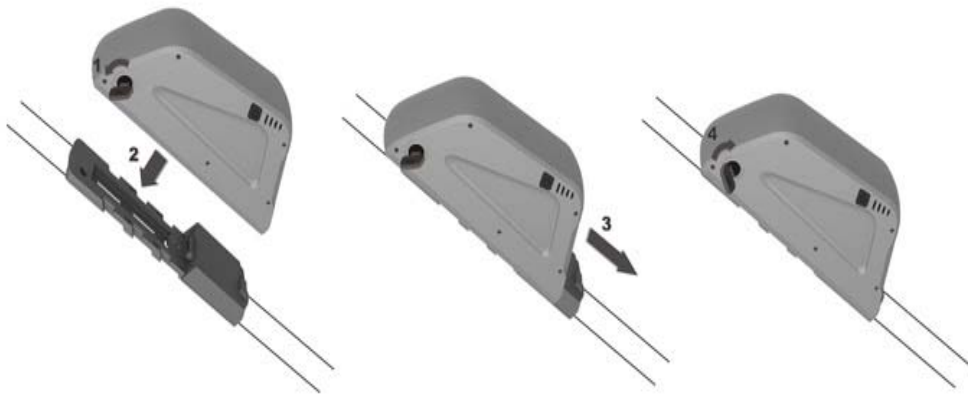

The battery should be slotted on the holder's rail and then drop down to connect with controller connector. Then battery should be locked with the key. Do not slot in the battery while it's in turned on.

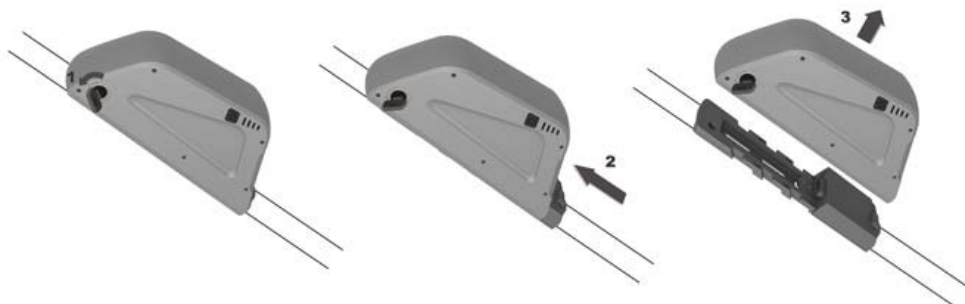

To remove the battery follow steps in the reverse order

## 5. Installing pedal assist sensor

The speed sensor that comes with the kit is designed to be fitted on the left hand side of the bottom bracket. It perfectly fit square taper axles but with minor modifications this can also be fitted to Shimano Octalink or ISIS drives.

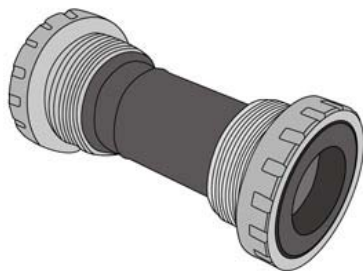

SM-BB51, SM-BB70

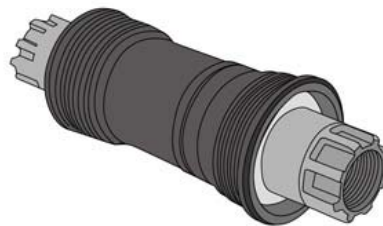

BB-ES25

For Octalink and ISIS the standard magnet needs the internal hole to be enlarged. To do that it's best to file it of.



## PAS sensor installation

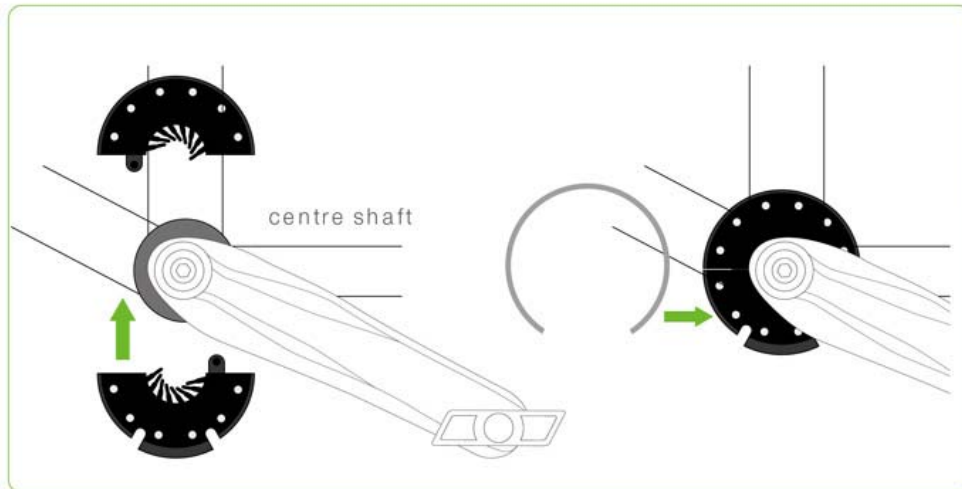

1. Assemble PAS disc, fasten metal ring to fix it.

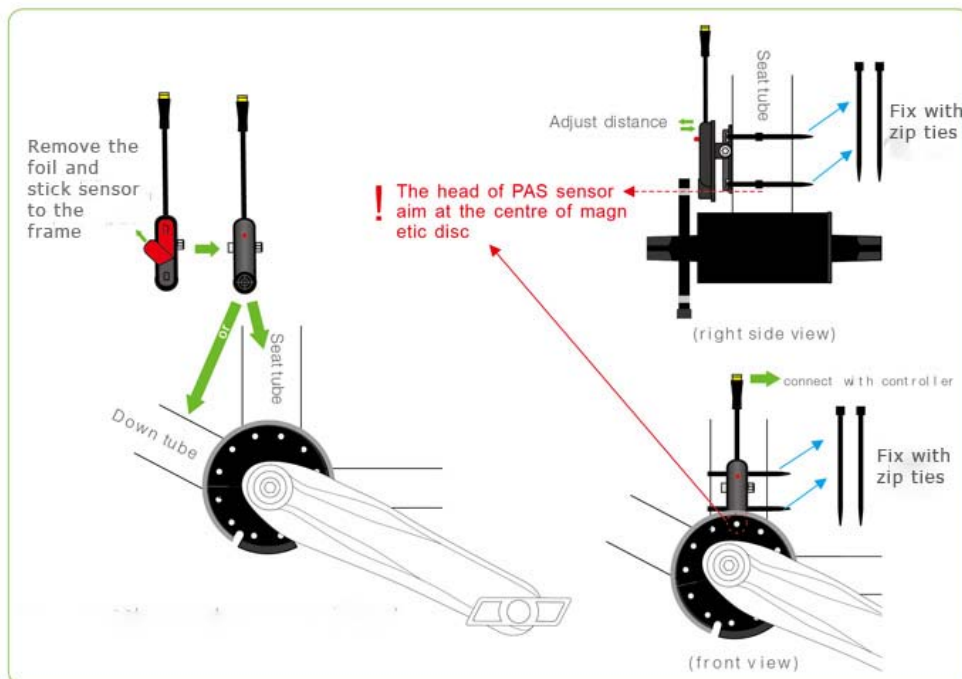

2. Assemble PAS sensor on middle tube or down tube, and fix with cable ties

The magnet disc should be fitted on the axle with magnets located approx 1-3mm from the speed sensor.

**IMPORTANT:** OXYDrive PAS sensor provided is currently compatible with the square tapered bottom brackets. In some case if the axle is too short or there is not enough room the bottom bracket might need to be replaced for the one with longer axle. This can be modified to fit Octalink and ISIS and Hollowtech cranks but if you have one of these systems please contact us about availability of special Octalink, Hollowtech sensors.

## 6. Fitting the LCD console

Currently there are two displays available for OXYDrive kits. C300 with buttons integrated in the display should be fitted on the left hand side.



In order to fit this display the handlebar grip, shifters and brake lever should be removed and the display should be slotted on the handlebars.

There is also another way of fitting this display by removing off the display the holding bracket and slotting it back when display is already on the handlebars.

## FITTING THE CENTRAL DISPLAY C6

In order to fit this display the handlebar grip, shifters and brake lever should be removed and the display should be slotted on the handlebars. The display should be located centrally in the middle of the handlebars.



Fitting the throttle and the power setting buttons will depend on the type of the bike and this has to be tried by each user. Throttle can be located on either left or right hand side of the handlebars. If fitted on the left the thumb twist will have to move forward then.

## 7. Installing the brake levers

Existing brake levers should be replaced by the brake levers supplied in the kit. The sensor from the lever should be plugged in directly into display's 2-pin connector. In order to fit the brake levers just remove the handlebar grips and slot the new levers and tight the securing bolt with 5mm hex key.

## 8. Connecting the connectors.

When connecting the connectors the extra caution shall be taken. Each connector has an arrow moulded on the surface. When joining connectors it is crucial that the arrows always are pointing out on each other. In this set the right pins meet their joining sockets.

**Please note that neglecting this step may cause the shortcuts in the entire system which will cause the permanent damage to the controller and the harness.**



## 9. Connecting the brake lever and throttle to the LCD console

The junction harness has been replaced by LCD console and now all connectors from the brake levers plug in directly into LCD display.

Brake levers plug in to 2-pin connector on the display

Throttle plugs in to 3-pin connector on the display



## **10. Using the LCD display**

Once the installation is completed please press the power button on the battery. The battery power is on when GREEN lights are ON the on the battery case.

In order to turn on the display press power button on the display for 1-2 seconds. The display will power on and will need approx 3 seconds to load up all functions.

Both displays C300 and C6 show variety of functions including speed, power level, level of pedal assist, level of load or even voltage on battery (C6 only).

With button set you can change the functions such as ODO, TRIP 1, TRIP

With buttons up and down you can change the level of pedal assist mode.

MODE 0 – no assist

MODE 1 – the weakest pedal assist

...

MODE 6 – the most powerful and fastest mode at the same time

### **RE-SETTING THE DAILY TRIP**

You need to press SET for 3 seconds, then press SET button once again until in mode figure will change from 0 to 1, then press UP or DOWN button and this will reset daily distance.

### **CHOOSING ACCELERATION MODE**

OXYDrive allows to choose one of the three acceleration modes, POWER, MID and ECO. Press SET for 3 seconds, then with up or down button you can choose from of the three power modes.

Please note that this setting does not affect speed but only acceleration

### **SETTING THE WHEEL SIZE**

Press SET button for 3 seconds, then press SET again two more times so the mode figure will change from 0 to 2, then with up or down button you can select required wheel size.

### **CHANGING KM/H to MPH**

Press SET for 3 seconds, then press SET again 3 times so the mode figure changes from 0 to 3, then with up or DOWN button you can change km/h to mph.

### **EXIT FROM SETTINGS MODE**

Once being in settings mode do not touch any buttons for 3 seconds, this will exit settings mode automatically.

### **RESTRICTING/ DERESTRICTING the throttle from 6km/h to full speed**

Press SET button for 12 seconds, when display enters advanced settings mode press SET again, then with up or down button change figure from 0 to 6km/h to restrict throttle to 6km/h. Do nothing for 3 seconds to exit settings mode

**PLEASE NOTE: In the EU Countries it is ILLEGAL to ride the bicycle on public highway powered by pure throttle at speeds higher then 6km/h. It is always riders responsibility to ensure that the controller is set to the legal settings.**

Thanks for reading, if you still have any questions please email us at [sales@oxydrive.co.uk](mailto:sales@oxydrive.co.uk) or call directly on +447738866502 or +442081230639